POS22-LD6C-T1

Features

- u Single Fiber XGS-PON ONU Transceiver
 - 1270nm burst-mode 9.953 Gb/s transmitter with DFB laser
 - 1577nm continuous-mode 9.953Gb/s APD/TIA receiver
- u Digital diagnostic monitoring (DDM)with internal calibration
- u SFP+ package with SC UPC receptacle connector
- u +3.3V separated power supply, low power dissipation
- u LVPECL interface logic level for data input
- u CML interface logic level for data output
- u LVTTTL for burst signal input
- u LVTTTL for receiver loss of signal detect indication
- u Compliant with ITU-T G.9807
- u SFF-8472 compliant
- u Telcordia GR-468-CORE and MIL-STD-883 compliant
- u RoHS-6/6 compliant
- ◆ Operating temperature range: 0°C ~ +70°C
- ◆ IEC 60825-1 compliant
- ◆ FCC Part 15 Class B /EN55022 Class B (CISPR 22B)/ VCCI Class B compliant

Applications

- u 10-Gigabit-capable passive optical networks

Description

The POS22-LD6C-T1 10/10G XGS-PON ONU transceiver is designed for single mode fiber and operates at wavelength of 1270nm. The transceiver module uses a DFB laser diode and fully compliant with IEC60825 and CDRH class 1 eye safety. It contains APC functions, a temperature compensation circuit to ensure compliance with ITU-T G.9807requirements at operating temperature.

The receiver section uses a hermetic packaged APD-TIA (APD with trans-impedance amplifier) and a limiting amplifier. The APD converts optical power into electrical current and the current is transformed to voltage by the trans-impedance amplifier. The differential DATA and /DATA CML data signals are produced by the limiting amplifier. The APD-TIA is AC coupled to the limiting amplifier through a low pass filter.

Specification

Absolute Maximum Ratings					
Parameter	Symbol	Min.	Max.	Unit	Note
Storage Ambient Temperature	T _{STG}	-40	+85	°C	
Case Operating Temperature	T _c	0	+70	°C	
Relative Humidity	RH	5	95	%	
Input Voltage	V _{CC}	-0.5	4	V	
Receiver Damaged Threshold	Pin	5		dBm	

Recommended Operating Conditions						
Parameter	Symbol	Min.	Typ.	Max.	Unit	Note
Power Supply Voltage	V _{CC}	2.97	3.3	3.63	V	1
Power Supply Current	I _{CC}			550	mA	
power dissipation	P _W			2	W	2
Operating case Temperature	T _{case}	0		+70	°C	
Power Supply Noise Rejection (peak – peak)	PSNR	100			mV	

Note 1: When the Power Supply Voltage between $3.3V \pm 5\%$, must ensure that all modules characteristics meet the requirements; within 3~3.6V, the module should be able to work, shall not be shut off, but the characteristics are allowed a certain degree to reduce characteristics.

Note 2: Measured with upstream /downstream 9.953G, PRBS2³¹-1, 70°C.

Transmitter Optical and Electrical Characteristics						
Parameter	Symbol	Min.	Typ.	Max.	Unit	Note
Transmitter type	DFB					
Data Rate	BR		9.953		Gb/s	
Optical Transmitter Power	P _{OUT}	5		9	dBm	1,BOL
		4		9	dBm	1,EOL
Output Center Wavelength	λ _C	1260	1270	1280	nm	
Output Spectrum Width (-20dB)	Δλ			1	nm	
Side Mode Suppression Ratio	SMSR	30			dB	
Output Power At Transmit Off	P _{OFF}			-45	dBm	
Extinction Ratio	ER	6.5			dB	
Tolerance to Tx Back Reflection	RL			12	dB	
Transmitter Reflectance				-10	dB	
Transmitter and Dispersion penalty	TDP			1.5	dB	
Tx_Burst Enable Time	T _{on}			30	ns	
Tx_Burst Disable Time	T _{off}			30	ns	
Optical Eye Diagram	Compliant With ITU-T G.9807					2,3
Initial Time	T _{ini}			800	ns	
Data Input Differential Swing	V _{IN}	200		1600	mV	
Input Differential Impedance	Z _{IN}		100		Ω	

TX_burst - Enable		0		0.8	V	
TX_burst - Disable		2.0		V _{cc} +0.3	V	
Tx_Fault - Fault		2.4		VCC	V	
Tx_Fault - Normal		0		0.4	V	
Tx_SD - High		2.4		VCC	V	
Tx_SD - Low		0		0.4	V	
TX Transmitter State Indication Turn ON Time	T _{INDL_ON}			200	ns	
TX Transmitter State Indication Turn OFF Time	T _{INDL_OFF}			200	ns	

Note 1: Launched into 9/125um SMF.

Note 2: Measured with PRBS 2³¹-1 @9.953Gbit/s, and the 4thBessel-Thompson filter is turned on.

Note 3: Transmitter eye mask definition inITU-T G.9807

Note 4: Included Tx_Burst,(See Pin Function Definitions).

Note 5: Included Tx_SD, Tx_Fault,LOS (See Pin Function Definitions).

Receiver Optical and Electrical Characteristics						
Parameter	Symbol	Min.	Typ.	Max.	Unit	Notes
Receiver type	APD/TIA					
Data rate	BR		9.953		Gb/s	
Operating Wavelength	λ _C	1575	1577	1580	nm	
Receiver Sensitivity	P _{SEN}			-29	dBm	1,BOL
Receiver Sensitivity	P _{SEN}			-28.5	dBm	1,EOL
Receiver Sensitivity	P _{SEN}			-24	dBm	2,EOL
Overload Input Optical Power	P _{SAT}	-8			dBm	
Maximum Input Optical Power	P _{MAX}	+5			dBm	
LOS Assert	P _{LOSA}	-39			dBm	3
LOS De-Assert	P _{LOSD}			-29	dBm	4
LOS Hysteresis	P _{LOSD} -P _{LOSA}	1		5	dBm	λ=1577nm
Receiver Reflectance				-20	dB	λ=1577nm
1310nm Tx to 1577nm Rx Crosstalk				-47	dB	
Optical Isolation From External Source	ISO ₁	35			dB	λ =1560nm
Optical Isolation From External Source	ISO ₂	35			dB	λ =1600nm
Data Output Differential Swing	V _{OUT}	340		850	mV	5
RX_LOS - Low		0		0.4	V	
RX_LOS - High		2.4		V _{cc}	V	
LOS Assert Time	T _{ASS}			100	us	
LOS De-Assert Time	T _{DAS}			100	us	

Note 1: P_{SEN} Measured with a PRBS $2^{31}-1$ test pattern @9.953 Gbit/s, BER = 10^{-3} .

Note 2: P_{SEN} Measured with a PRBS $2^{31}-1$ test pattern @9.953 Gbit/s, BER = 10^{-12} .

Note 3: A decrease in optical power below the specified level will cause the Loss of Signal output to switch from a low state to a high state.

Note 4: An increase in optical power above the specified level will cause the Loss of Signal output to switch from a high state to a low state.

Note 5: CML output, AC coupled internally, guaranteed in the full range of input optical power.

Digital Diagnostic Memory Map

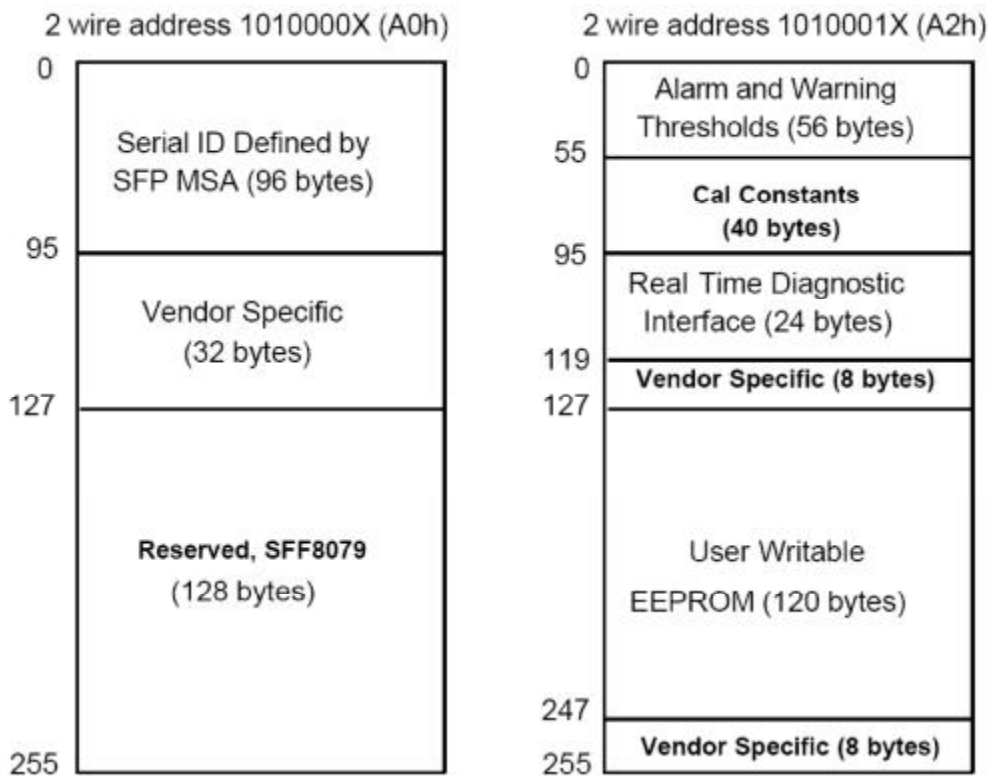

Figure1

EEPROM Serial ID Memory Contents

The module provides digital diagnostic information of its operating conditions and status, including transmitting power, received power, laser bias current, module temperature, and supply voltage. Calibration and alarm/warning threshold data are written and stored in internal memory. The memory map is compatible with SFF-8472

Digital Diagnostic Monitoring Information

Parameter	Range	Resolution	Accuracy	Repeatability	Typical response time	Notes
Temperature	-45 to 90°C	0.25°C	±3°C	±1°C	1S	
Voltage	2.97to 3.63V	0.5%	±3%	±1%	1S	
TX Power	2~11dBm	0.1dB	±2.0dB	±0.5dB	300nS	1
Bias Current	1~100mA	1%	±10%	±5%	1S	
RX Power	-30~-7dBm	0.1dB	±2.0dB	±0.5dB	300nS	

Note 1:For the TX Power DDM and TX Power alarm& warning thresholds, the LSB is 0.2 μ w.

Pin Description

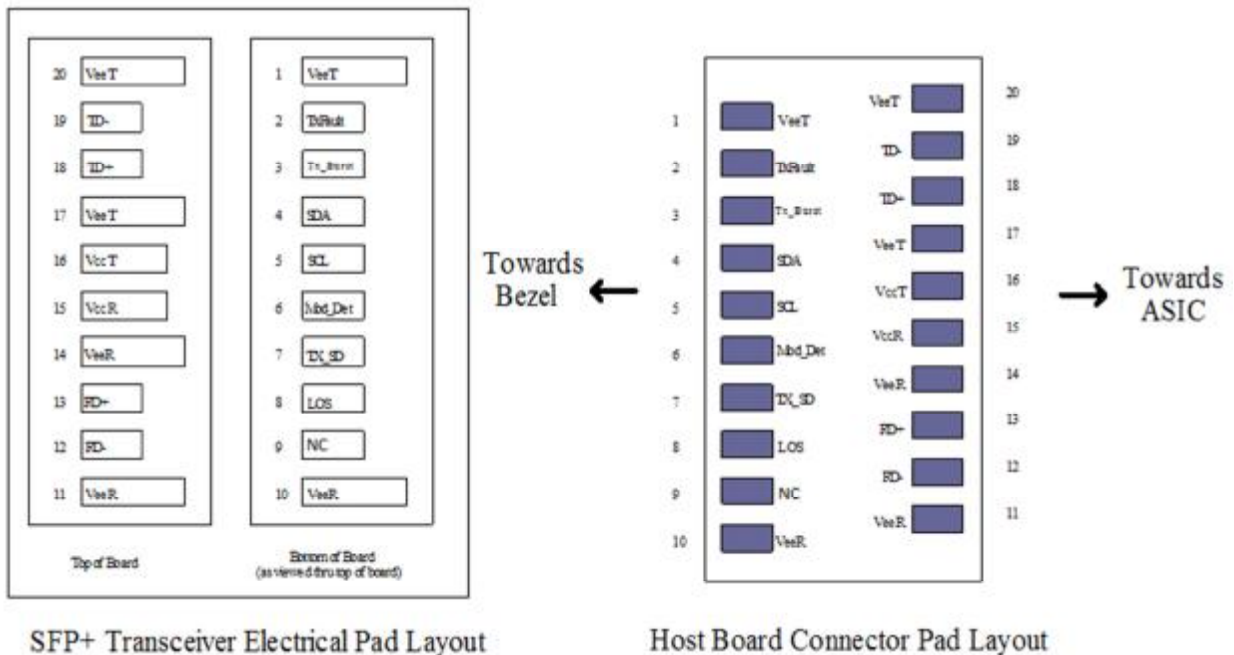

Figure2

Pin Num.	Name	Function	Note
1	VeeT	Transmitter Ground	1
2	Tx Fault	LVTTTL, Transmitter Fault indication, Low=Normal operation, High= TX Fault	2
3	Tx_Burst	LVTTTL ,Transmitter Burst control,logic "0" to burst on	3
4	SDA	Module Definition 2, SDA Serial Data Signal	4
5	SCL	Module Definition 1, SCL Serial Clock Signal	4
6	MOD_Det	Connected to the ground internal	4
7	TX_SD	LVLLT, Transmitter signal detect	

8	LOS	LVTTTL, Loss of Signal, need external 4.7k~10k pull up resistor	5
9	NC	NC	8
10	VeeR	Receiver Ground	1
11	VeeR	Receiver Ground	1
12	RD-	Inv. Received Data Out,AC/CML	
13	RD+	Received Data Out,AC/CML	
14	VeeR	Receiver Ground	1
15	VccR	Receiver Power	
16	VccT	Transmitter Power	
17	VeeT	Transmitter Ground	1
18	TD+	Transmit Data In,AC/ LVPECL	6
19	TD-	Inv. Transmit Data In,AC/ LVPECL	6
20	VeeT	Transmitter Ground	1

Note 1: VeeR and VeeT internally connected within the PON module.

Note 2: TX Fault indicates the status of module with pull up resistor of 10 KΩ externally. In the low state, the output will be pulled to < 0.4V.

Note 3:TX_burst is an input that is used to shut down the transmitter optical output. It is pulled up within the module with a 10 KΩ resistor.

Note 4: These are the module definition pins.

SDA is serial data signal with 10 KΩ pull up resistor externally.

SCL is serial clock signal with 10 KΩ pull up resistor externally.

MOD_Det is grounded internally and need 10 KΩ pull up resistor externally to indicate that the module is present.

Note 5: LOS (Loss of Signal) indicates the status of received optical power with 10 KΩ pull up resistor externally.

Note 6: TD-/+ : These are the differential transmitter inputs. They are AC-coupled, differential lines with 100Ω differential termination inside the module. The AC coupling is done inside the module and is thus not required on the host board.

Function Description

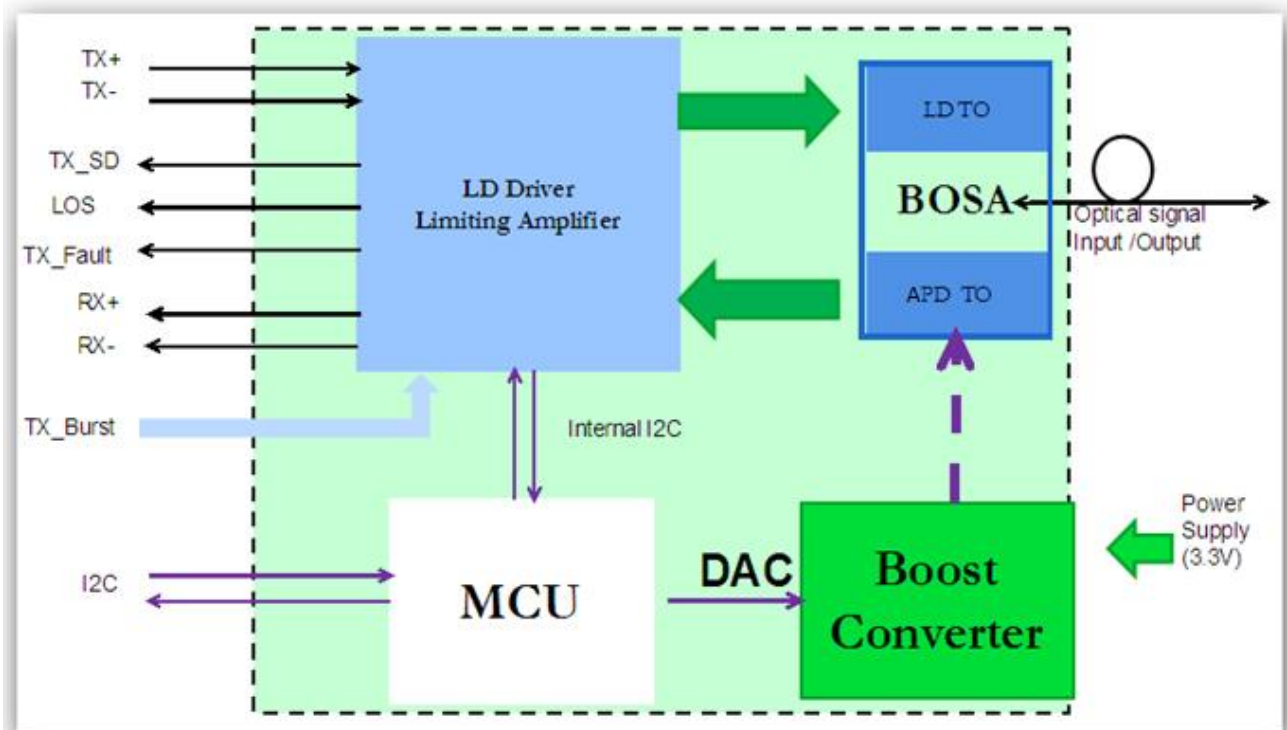

Figure3 Block diagram

The burst-mode transmitter part has a 1270nm DFB laser. It features AC-coupled differential data inputs. Tx_Burst is a LVTTTL input for TX shut down control. Logic "1" disables the LD driver.

The 1577nm continuous-mode receiver part has a high performance detector. The preamplifier (TIA) and limiting amplifier amplify the incoming optical signal into the stable range and convert the signal to differential AC-coupled CML outputs. LOS is LVTTTL output, which logic "1" indicates the input power is lower than the threshold, logic "0" indicates the input power is above the threshold.

Interface Circuit

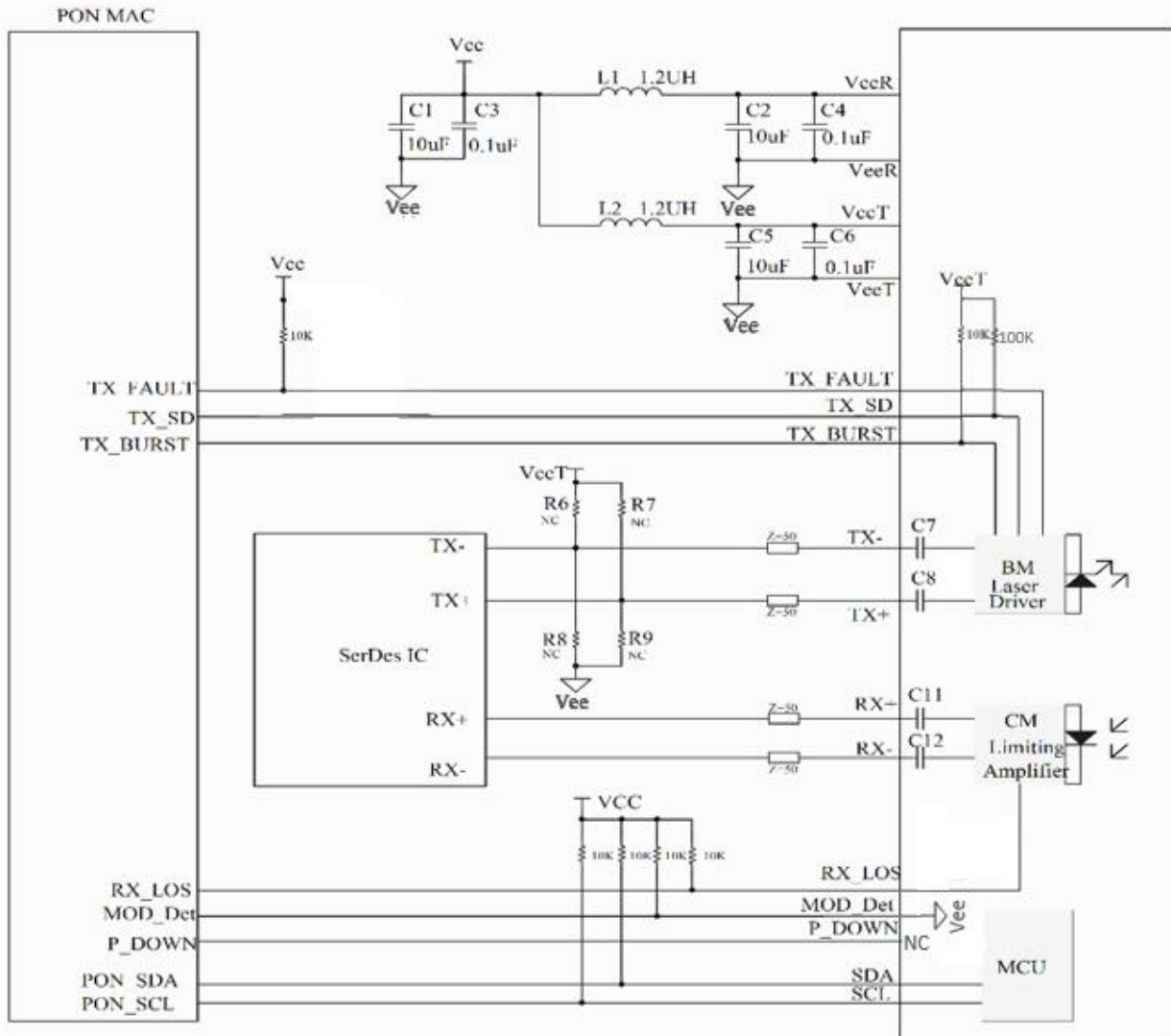

Figure4

Package Outline

(Unit: mm)

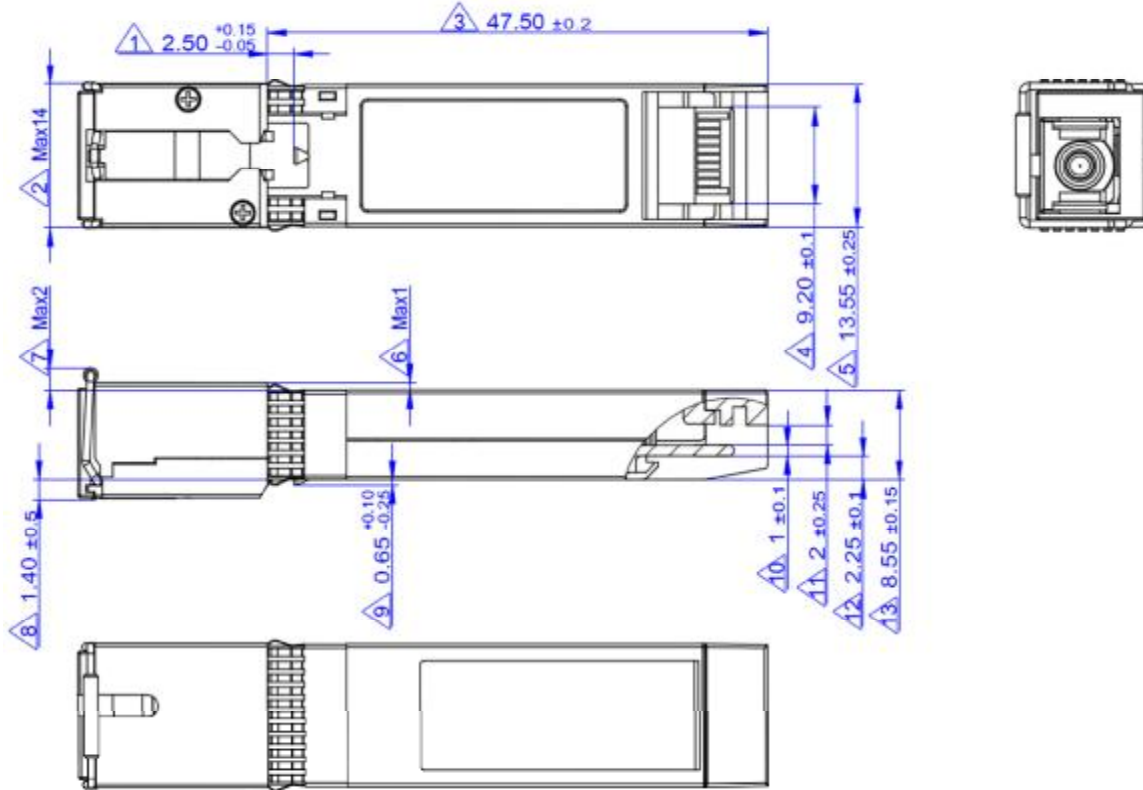

Figure5

Ordering information

PART NO.	Specifications								
	Type	Rate Tx/Rx	Tx (nm)	Po (dBm)	Rx (nm)	Sen (dBm)	Temp (°C)	DDM	Others
POS22-LD6C-T1	SFP+	10G/10G	1270/DFB	5~9	1577/APD	<-29	0~70	Y	SC UPC Receptacle BIDI, Low-Burst On