XTE80-D0C-T1

Features

- ◆ Up to 9.95 Gbps to 11.3Gbps
- ◆ 1550nm cooled EML Laser and APD photo detector
- ◆ Duplex LC receptacle optical interface compliant
- ◆ 3.3V power supplies required
- ◆ Hot-pluggable
- ◆ AC coupling of CML signals
- ◆ International Class1 laser safety certified
- ◆ Operating temperature range:
Commercial:0°C ~+70°C
- ◆ RoHS Compliant
- ◆ DDMI function available with internally calibrated mode

Application

- ◆ SONET OC-192 &SDH STMI-64.1
- ◆ 10Gigabit Ethernet
- ◆ 10Gigabit Fiber Channel

Standard

- ◆ Compliant with IEEE802.3ae
- ◆ Compliant with INF-8077

Specification:

Absolute Maximum Ratings				
Parameter	Symbol	Min	Max	Unit
Storage temperature	TS	-40	85	°C
Power Supply Voltage	Vcc3	-0.5	+4	V
Relative Humidity	RH	5	95	%

Recommended Operating Conditions					
Parameter	Symbol	Min	Typical	Max	Unit
Operating Case Temperature	Tc	0		70	°C
Power Supply Voltage	Vcc3	3.13	3.3	3.47	V
Supply Current ¹	Icc3			750	mA
Data Rate		9.95		11.3	Gbps
Fiber Length 9/125µm core SMF		-		80	km

Electrical Characteristics						
Parameter	Symbol	Min	Typical	Max	Unit	Notes
Power dissipation	P			3.5	W	
Transmitter differential input voltage		120	-	820	mV	
Receiver differential output Voltage		300	650	850	mV	
Transmit disable voltage	V _{IH}	2.0		Vcc+0.3	V	LVTTTL
Transmit enable voltage	V _{IL}	-0.3		0.8	V	LVTTTL
Transmit disable assert time				10	us	
Loss of Signal (LOS)	V _{OH}	2.4		Vcc+0.3	V	LVTTTL
	V _{OL}	-0.3		0.4	V	LVTTTL
Leakage Current	I _L	-10		10	µA	
I2C Clock Rate				400	KHz	

Optical transmitter Characteristics						
Parameter	Symbol	Min	Typical	Max	Unit	Notes
Launched Power (avg.)	Pout	0		5	dBm	

Operating Wavelength Range	λ_c	1500	1550	1570	nm	
Spectral Width (-20dB)	$\Delta\lambda$			0.5	nm	
Side Mode Suppression Ratio	SMSR	30			dB	
Extinction Ratio	ER	8.2			dB	2
Transmitter and Dispersion Penalty	TDP			2	dB	
Relative Intensity Noise	RIN			-128	dB/Hz	
Optical Rise/Fall Time	Tris/Tfall	28			PS	3
Optical Tx Output disable	P_{dis}			-45	dBm	
Output Eye Diagram	Compliant with ITU-T G.691 eye mask and STM-64 eye mask					
Optical receiver Characteristics						
Parameter	Symbol	Min	Typical	Max	Unit	Notes
Receiver Sensitivity	S			-24	dBm	4
Wavelength Range	λ_c	1260		1610	nm	
Receiver Reflectance				-27	dB	
Optical Power Input Overload	P_{in-max}	-8			dBm	4
LOS	Optical De-assert	P_d		-25	dBm	4
	Optical Assert	P_a	-39			
LOS hysteresis		0.5		5	dB	5

Note1. The supply current is XFP module's working current.

Note2: For the measurements, the device was driven with 9.953Gbps data pattern with $2^{31}-1$ PRBS payload

Note3. Optical transition time is the time interval required for the rising or falling edge of an optical pulse to transition between the 20% and 80% amplitudes relative to the logical 1 and 0 levels

Note4. Measured with a PRBS $2^{31}-1$ test pattern, @10.3125Gbps, ER=8.2dB, BER< 10^{-12}

Note5. The LOS Hysteresis minimizes 'chatter' on the output line. In principle, Hysteresis alone does not guarantee chatter-free operation.

Digital Diagnostic Monitoring Information

Parameter	Accuracy	Calibration	Range
Temperature	$\pm 3^\circ\text{C}$	internal	0~70°C
Voltage	$\pm 3\%$	internal	3.1~3.5V
Bias Current	$\pm 10\%$	internal	Specified by normal value
TX Power	$\pm 2\text{dB}$	internal	0~5dBm
RX Power	$\pm 3\text{dB}$	internal	-24~-8dBm

Pin Description

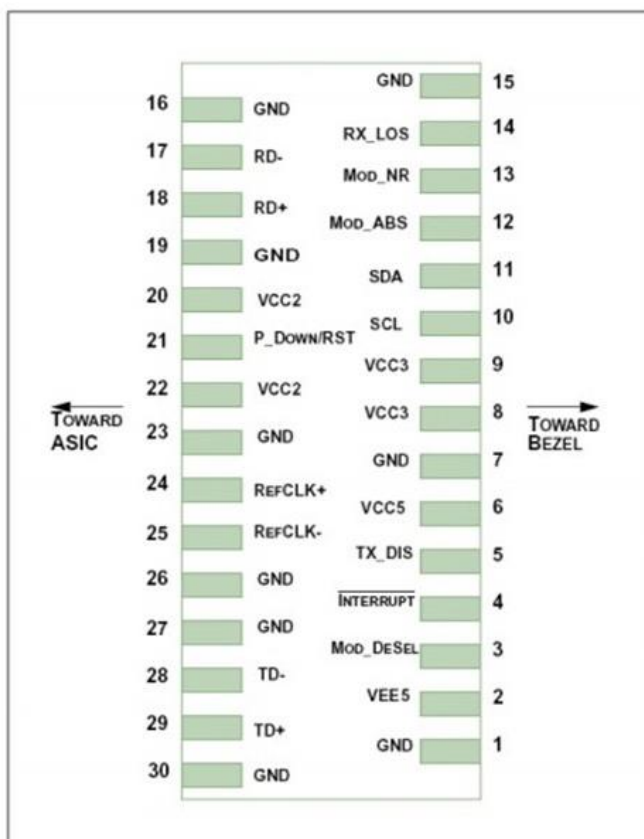

Pin Assignment

Pin	Logic	Symbol	Description	Note
1		GND	Module Ground	1
2		VEES	Optional -5.2V Power Supply(Not Required)	
3	LVTTL-I	Mod DeSel	Reverse data output of receiver section	
4	LVTTL-O	PECL	Optical alarm of receiver section, High level when normal, low level when no light	2
5	LVTTL-I	Interrupt	Interrupt;Indicates presence of an important conditionof an important condition which can be read over the 2-wire serial interface	
6		Vcc	+5V Power Supply (Not Required)	
7		GND	Module Ground	1
8		VCC3	+3V Power Supply	
9		VCC3	+3V Power Supply	
10	LVTTL-I/O	SCL	2-Wire Serial Interface Clock	2

11	LVTTTL-I/O	SDA	2-Wire Serial Interface Data Line	2
12	LVTTTL-O	Mod_Abs	Indicates Module is not present. Grounded in the Module	2
13	LVTTTL-O	Mod_NR	Module Not Ready; Indicating Module Operating Faulty	2
14	LVTTTL-O	RX_LOS	Receiver Loss Of Signal Indicator	2
15	-	GND	Module Ground	1
16	-	GND	Module Ground	1
17	CML-O	RD-	Receiver Inverted Data Output	
18	CML-O	RD+	Receiver Non-Inverted Data Output	
19		GND	Module Ground	1
20		VCC2	+1.8V Power Supply	
21	LVTTTL-I	P_Down/ RST	Power down; When high, requires the module to limit power consumption to 1.5w or below. 2-Wire serial interface must be functional in the low power mode. Reset;The falling edge initiates a complete reset of the module including the 2-wire serial interface, equivalent to a power cycle.	
22		VCC2	+1.8V Power Supply	
23		GND	Module Ground	
24	PECL-I	RefCLK+	Reference Clock Non-Inverted Input, AC coupled on the host board (Not Required)	
25	PECL-I	RefCLK-	Reference Clock Inverted Input, AC coupled on the host board (Not Required)	
26		GND	Module Ground	1
27		GND	Module Ground	1
28	CML-I	TD-	Transmitter Inverted Data Input	
29	CML-I	TD+	Transmitter Non-Inverted Data Input	
30		GND	Module Ground	1

Note1. Module ground pins GND are isolated from the module case and chassis ground within the module.

Note2. It shall be pulled up with 4.7K-10Kohms to a voltage between 3.15V and 3.45V on the host board.

Block Diagram

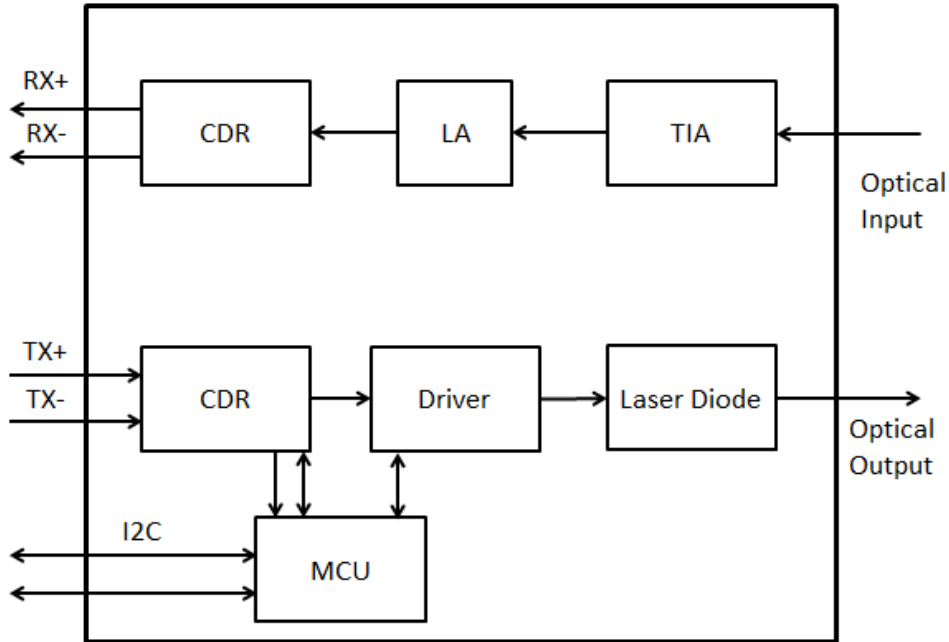

Typical Application Circuit For Power Supply

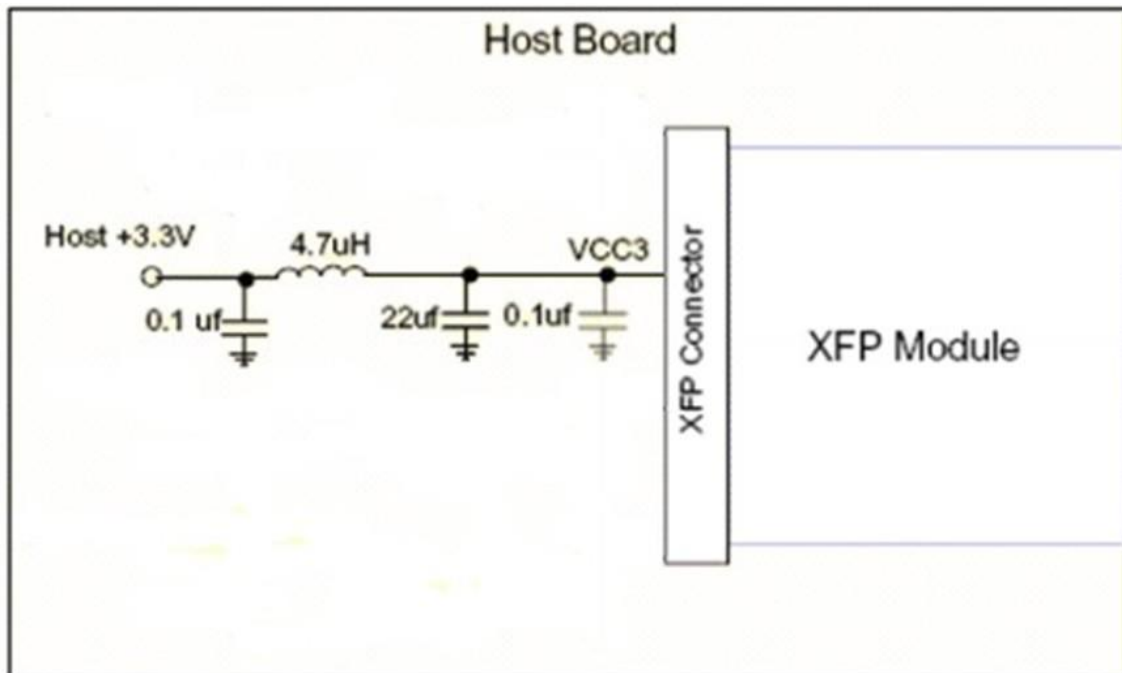

Digital Diagnostic Memory Map

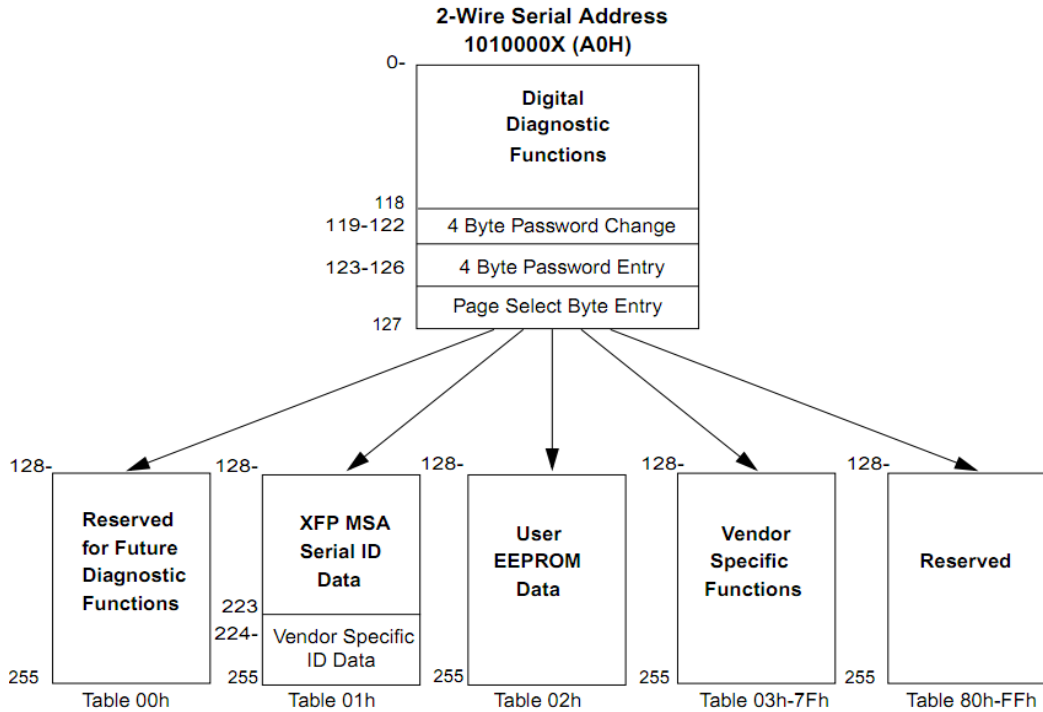

Package Outline

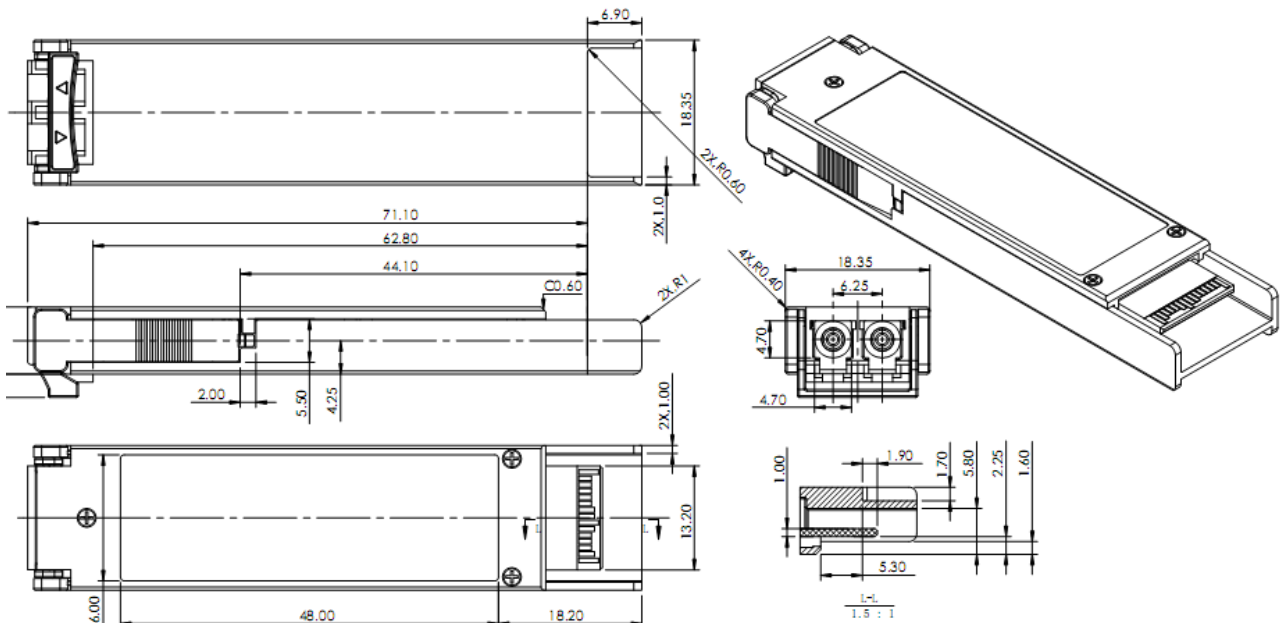

Unit:mm
Unspecified tolerance:±0.1mm

Regulatory Compliance

Feature	Test	Method
Electrostatic Discharge (ESD) to the Electrical Pins	MIL-STD-883E Method 3015.7	Class 1(>1000V for SFI pins, >2000Vfor other pins.)
Electrostatic Discharge (ESD) Immunity	IEC61000-4-2	Class 2(>4.0kV)
Electromagnetic Interference (EMI)	CISPR22 ITE Class B FCC Class B CENELEC EN55022 VCCI Class 1	Comply with standard
Immunity	IEC61000-4-3	Comply with standard
Eye Safety	FDA 21CFR 1040.10 and 1040.11 EN (IEC) 60825-1,2	Compatible with Class I laser Product

Ordering information

Part. No	Specifications								
	Pack	Rate (Gbps)	Tx (nm)	Po (dBm)	RX	Sen (dBm)	Temp (°C)	Reach (km)	DDM
XTE80-D0C-T1	XFP	9.95~11.3	1550	0~5	APD	<-24	0~70	80	Y